

# ID MOUNTED FLANGE FACER

## IMFM-30 - FLANGE FACER



Internally mounted, lightweight super rigid yet super heavy-duty machine tool. Ideal for machining all types of flange faces, seal grooves, weld preparations and counterbores.

- ▶ Heavy-duty steel/aluminium design
- ▶ Heavy-duty cast steel body and steel body plate
- ▶ Solid construction and high rigidity of the machine in relation to the dimension and weight
- ▶ Continuous groove facing feed, 2-speed gearbox
- ▶ Swivel tool post for grooves, RTJ flanges and bevels
- ▶ Easy levelling and centring system with built-in fast centre feature
- ▶ Quick clamping with solid 50mm self-centring steel shaft
- ▶ CE certified

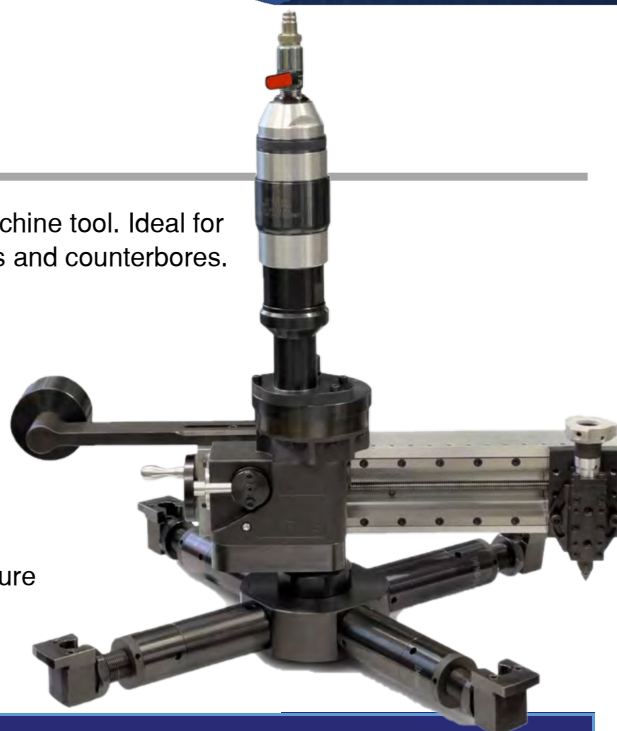

Standard Working Range			Facing Feeds			Free Speed	Power
Facing Range	Locking range	1.75mm Screw	1.25mm Screw	1.00mm Screw			
145-762mm	140-670mm	0.2 / 0.8mm	0.14 / 0.57mm	0.15 / 0.45mm	20-42 Rpm	2.2 Hp	
5-30.0"	5.5-26.0"	0.008 / 0.031"	0.006 / 0.022"	0.004 / 0.018"		1.6 Kw	

Air Use		Machine Weight		Body Height		Body Length	
75 cfm	2.2m <sup>3</sup> /min	108 Lbs	49kg	<i>Depends on motor configuration, see drawing below</i>			

### Complete Package

As standard, the IMFM-30 is supplied with a complete toolkit, including tool and inserts, air filter with lubricator and hose connection, required jaws to cover the full range, paper manual and storage/shipping box. Beside standard pneumatic 2.2Hp drive, we offer a wide range of pneumatic and electric drives for the IMFM-30.

### Wide Range

Machine is equipped with 2 locking bases.  
 Small base - 140-290mm  
 Big base - 250-700mm



### Unique Rigidity

High rigidity of the machine in relation to the dimension and weight by applying Heavy-duty cast steel body and steel body plate.



### Tooling Chart

Holder	Insert	Screw	Torx
IMFM24-V11	CIV-11-3-1	MHS-4	TX-15

+44 (0) 23 8036 6410

tuberunner@bsa-regal.co.uk



www.tuberunner.co.uk

### Swivel Tool

Swivel tool post for grooves, RTJ flanges and bevels

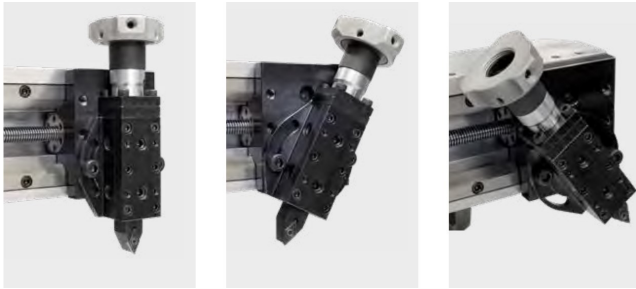

### Convenient Jaws

Special jaw set for easy and quick levelling and centring machine. A special mechanism allows convenient adjustment of the mounting plane relative to the pipe. Jaws are interchangeable and all IMFM series flange facers.



### Precise mounting



### Fast Fixing

Super fast machine fixing with locking base by means of taper in the locking base and taper seat in the spindle, fastened with a central locking screw.

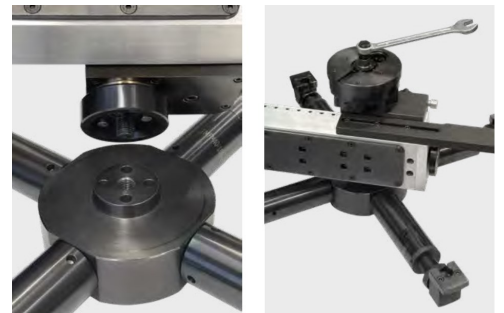

Fast mounted arm with spindle for convenient measuring of levelling and centring.

### Right Angle Head



This optional addon allows for fastening drive in alternate positions. A useful option in tight spaces.

### Electric Drive

As an option, we can deliver the electric motor, made by Makita. With our 3 stage planetary gear box, the drive has variable speed control and produces enormous torque. It is interchangeable with pneumatic drive and can be purchased separately at any time.

Also available with battery driven motor!

- ▶ Free Speed - 115 Rpm
- ▶ Power - 750 W
- ▶ Torque - 360 Nm (266 Ft. Lbs)

