

ID MOUNTED FLANGE FACER

IMFM-24 - FLANGE FACER



Internally mounted, lightweight and durable machine tool. Ideal for machining all types of flange faces, seal grooves, weld preparations and counterbores.

- ▶ Heavy-duty steel/aluminium design
- ▶ High rigidity of the machine in relation to the dimension and weight
- ▶ Solid but lightweight construction
- ▶ Continuous groove facing feeds
- ▶ Swivel tool post for grooves, RTJ flanges and bevels
- ▶ Easy levelling and centering system with built-in fast centre feature
- ▶ Quick clamping with solid 50mm self-centering steel shaft
- ▶ CE certified

As standard, the IMFM24 is supplied with a complete tool kit, including tool and inserts, air filter with lubricator and hose connection, required jaws to cover the full range, paper manual and storage/shipping box. Beside standard pneumatic 2.2Hp drive, we offer a wide range of pneumatic and electric drives for the IMFM24.



Standard Working Range		Facing Feeds			Free Speed	Power
Facing Range	Locking range	1.75mm Screw	1.25mm Screw	1.00mm Screw		
100-610mm	100-508mm	0.2 / 0.8mm	0.14 / 0.57mm	0.15 / 0.45mm	20-42 Rpm	2.2 Hp
4-24.0"	4-20.0"	0.008 / 0.031"	0.006 / 0.022"	0.004 / 0.018"		1.6 Kw

Air Use		Weight		Body Height	Body Length
75 cfm	2.2m ³ /min	99 Lbs	45kg	<i>Depends on motor configuration, see drawing below</i>	

Levelling and Centering



Special jaw set for levelling and centering on a flange

Tooling Chart

Holder	IMFM24-V11
Insert	CIV-11-3-1
Screw	MHS-4
Torx	TX-15

Inline

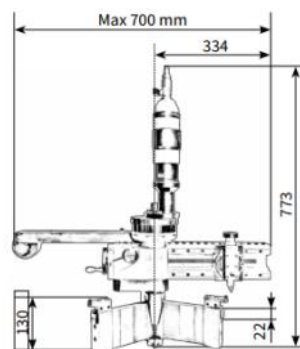

Rightangle

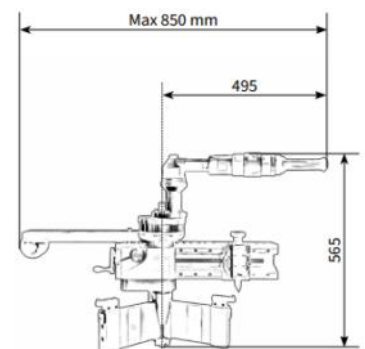

+44 (0) 23 8036 6410

tuberunner@bsa-regal.co.uk



www.tuberunner.co.uk